

(Current Processes)

**Purchase Order Invoices
Current Process**

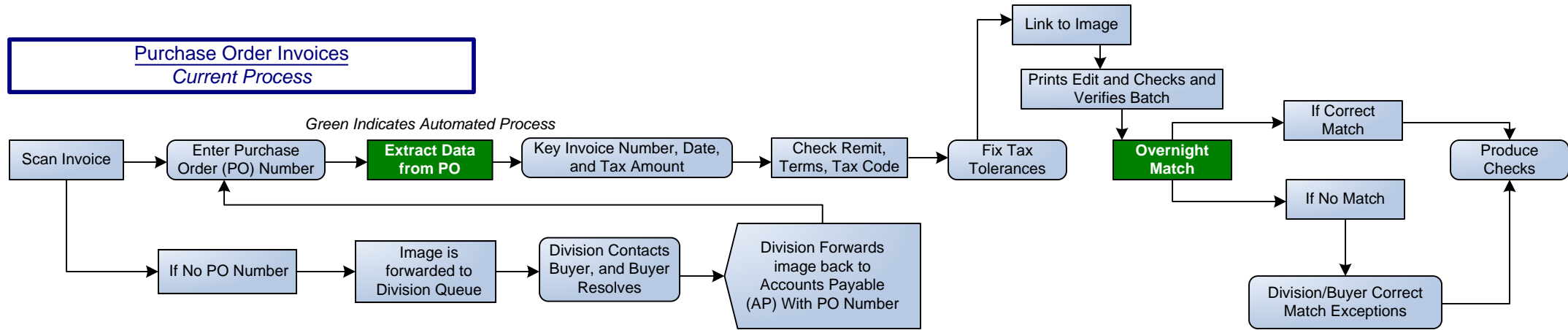

**Purchase Order Invoices
Current Process**

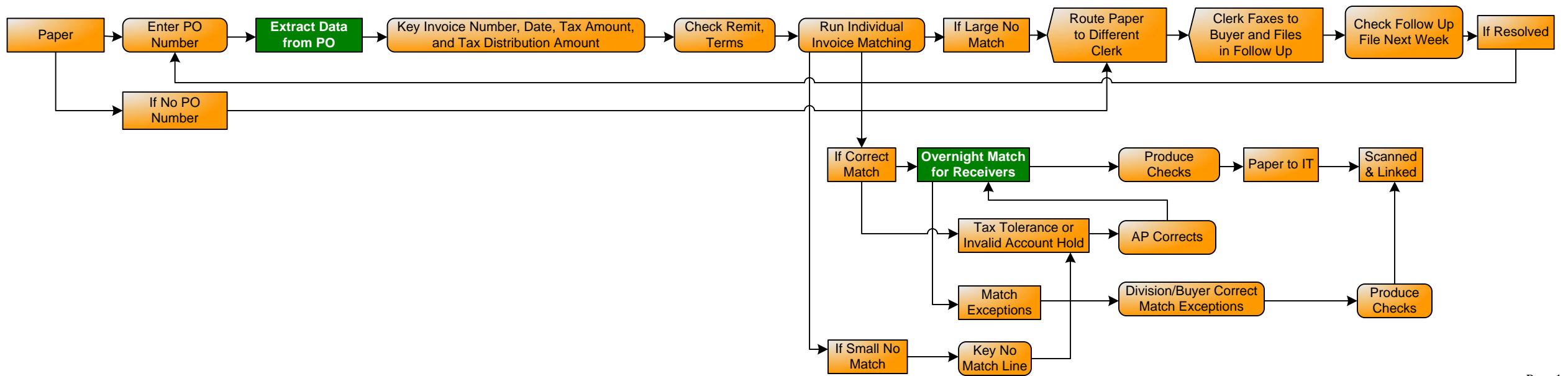

(Proposed Processes)

Purchase Order Invoices
Proposed Optical Character Recognition (OCR) Process

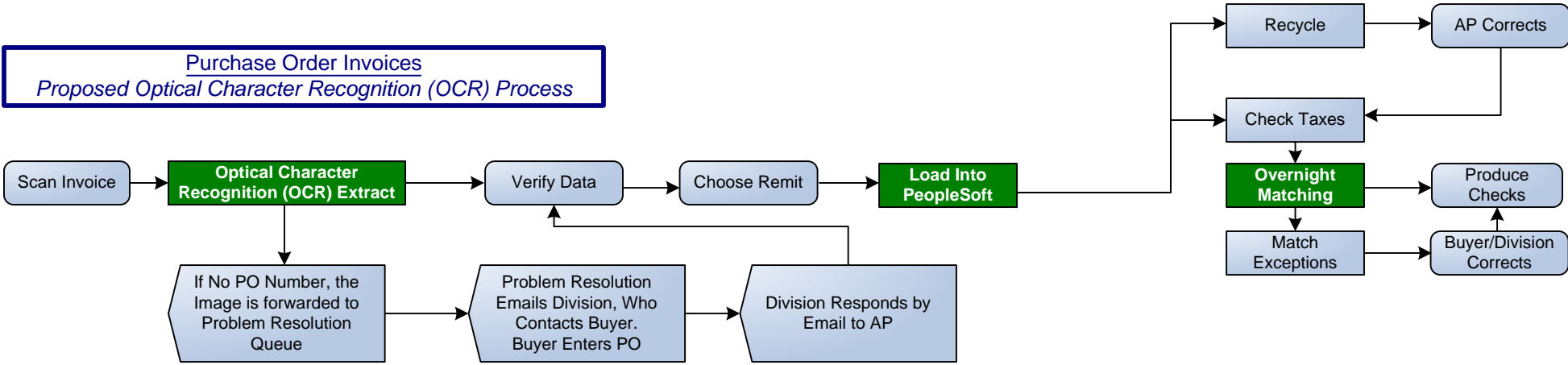

Purchase Order Invoices
Proposed Payables Invoice Processing System (PIPS) Process

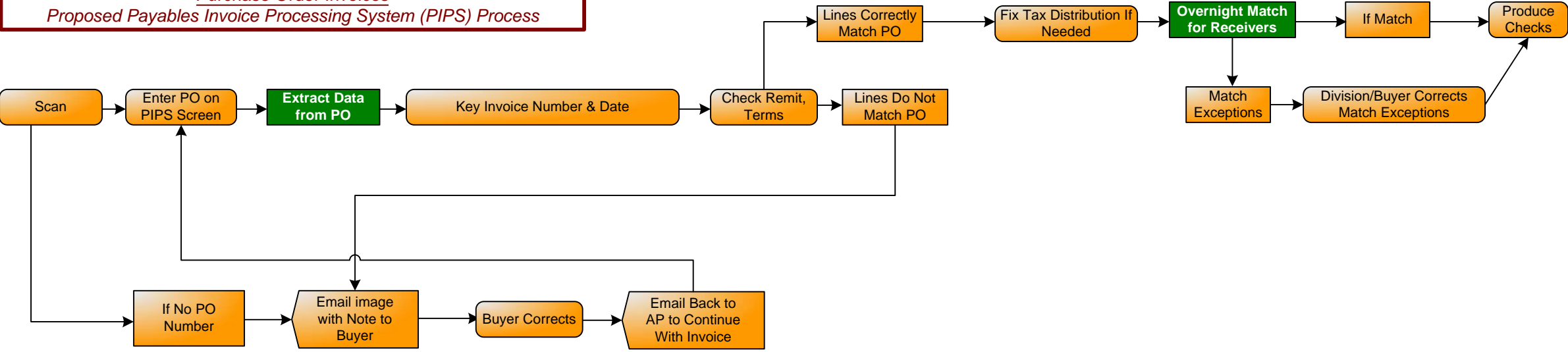

(Existing & Proposed Processes)

Non-Purchase Order Invoices
Current Process

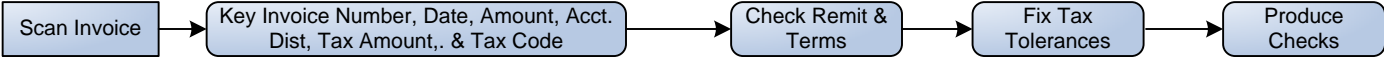

Non-Purchase Order Invoices
Current Process

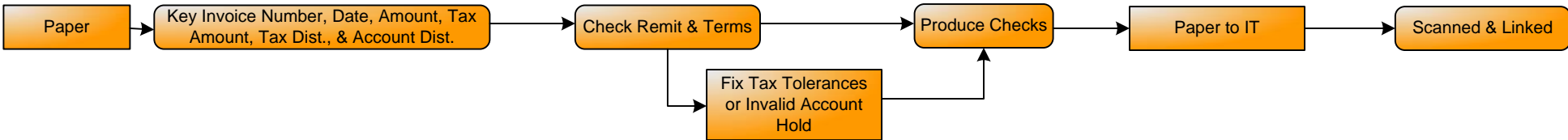

Non-Purchase Order Invoices
Proposed Process

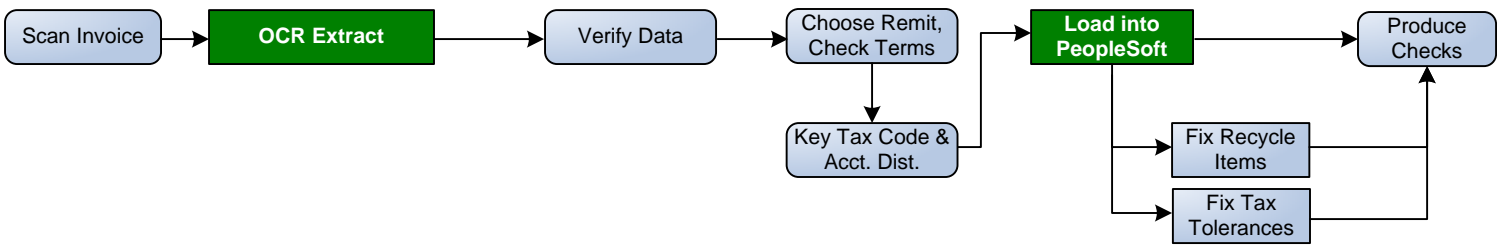

Non-Purchase Order Invoices
Proposed Process

